

LED PATHLIGHT - WALL MOUNT

Code: ELCH-P



FEATURES

- UL 1598 Listed, UL Wet Location Listed Standard NFPA 101, NEC, BOCA, OSHA and IBC illumination standards, Meets ADA specifications for wall mounted lighting fixtures
- Premium die cast aluminum housing painted in a powder coat finish
- All-in-one includes the LED light engine, integral power supply, three level intensity control and a single gang junction box mounting plate
- All LED and electrical components are protected by both a polycarbonate lens and high impact power supply case that will be located within the junction box
- Emergency Operation: Charging system is microprocessor driven with software embedded diagnostic routine and temperature compensation

WARRANTY INFORMATION

Any component that fails due to manufacturer's defect is guaranteed for 1 year. The warranty only covers products installed and maintained in accordance with the instructions provided by their respective manufacturer and no warranty is made with respect to any of our products that are otherwise installed or maintained. For full warranty details, visit our Warranty Section.

Conformance to Codes and Standards

The ELCH-P series is UL listed and meets or exceeds the following: UL 924, UL 1598, NEC, OSHA, BOCA and NFPA 101 Life Safety Code

The ELCH-P series is designed to support low-level illumination for stairwells, step landings, wheelchair ramps, and exit corridors.



ORDERING INFORMATION

Series	Finish Color	Input Voltage
ELCH-P	White	120VAC
	Black	12 AC,DC

CONSTRUCTION

The ELCH-P series light is constructed from premium die cast aluminum components and is painted in a durable powder coat finish. The LED and electrical components are protected by both polycarbonate lens and high impact power supply case that will be located within the junction box.

ILLUMINATION

The ELCH-P series with white LEDs operates at 3500K nominal with a minimum CRI of 80. The amber LEDs operate at a nominal wave length of 600nm.

ELECTRICAL COMPONENTS

The ELCH-P series is designed with solid state components and is rated for 10 years of continuous "normally on" use. It incorporates dip switches on rear of product allowing three levels of intensity.

INSTALLATION

The ELCH-P series is designed for direct mounting to a single gang junction box. When installing PathMaster in an outdoor damp or wet location, a single gang "FS" style junction box will be required by most local electrical codes.

DIMENSIONS

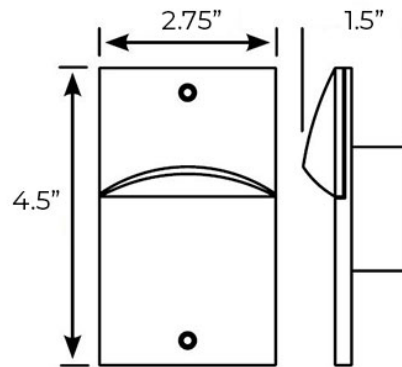

Width	2.75"
Height	4.5"
Depth	1.5"
Weight	9.00 lb

3170 Scott St, Vista, CA 92081
Phone: 877-352-3948 | Fax: 877-352-3949
info@exitlightco.com