



LED EXPLOSION PROOF EMERGENCY LIGHT | CLASS 1 DIVISION 1 | ADJUSTABLE LAMP HEADS

Code: ELX-C1D1



The ELX-C1D1 Series is not only ideal for wet locations, it seamlessly integrates energy-efficient LED technology with a robust enclosure, making it suitable for specialized locations



FEATURES

- Class I Division 1 Rated
- Multiple UL Listings and Certifications
- UL 844, 924, 1598A, 1598, 8750 (See Full List Below)
- Universal input voltage 120-277VAC
- Internal solid-state transfer switch
- Low Working Wattage for Energy Savings
- Two Adjustable High-lumen Spot Lights

WARRANTY INFORMATION

Any component that fails due to manufacturer's defect is guaranteed for 1 year. The warranty only covers products installed and maintained in accordance with the instructions provided by their respective manufacturer and no warranty is made with respect to any of our products that are otherwise installed or maintained. For full warranty details, visit our Warranty Section.

Conformance to Codes and Standards

The ELX-C1D1 is UL listed and meets and/or exceed multiple certifications; see "Certifications" section for a complete list.

ORDERING INFORMATION

Series	Housing Color	Operation Type	Wattage
ELX-C1D1	GR (Gray)	BB (Battery Backup)	10W
			12W

CONSTRUCTION

The ELX-C1D1 Emergency Light series is constructed from A360 die-cast aluminum with a gray finish. Housing has 3 (sides and bottom) threaded conduit holes for easy hookup. Designed with tamper-proof screws for unauthorized access to the unit.

ILLUMINATION

The ELX-C1D1 Emergency Light series is designed with two high-lumen fully adjustable LED lamp heads. Each lamp head is equipped with 12 LEDs putting out a total of 900lm. Beam angle is 90° or 120° and lamp adjustability is from 0° to 180° for optimized center to center spacing.

ELECTRICAL COMPONENTS

Universal 120-277 VAC operation. Unique LED indicator light. Unit offers surge protected, solid state circuitry. Battery backup models offer an external push button test switch, brownout detection, AC lockout, low voltage disconnect and visual LED system fault indicator.

EMERGENCY OPERATION

Upon failure of the normal utility power, an internal solid-state transfer switch automatically provides uninterrupted emergency operation for at least 180 minutes. The fully automatic solid-state, two-rate charger initiates recharging a discharged battery within 24 hours.

BATTERY - BATTERY BACKUP

The ELX-C1D1 Emergency Light series is designed with a maintenance-free 9.6V 4000 mAh rechargeable Li-Ion battery that provides a minimum emergency duration of 180 minutes. Recharge time of the battery is 24 hours.

OPERATIONAL TEMPERATURE

Temperature Ratings

Standard	-4°F to 140°F
----------	---------------

INSTALLATION

The ELX-C1D1 Emergency Light series is suitable for wall mount installation with its stainless steel mounting brackets. It's recommended to use 7/16" bolts to mount the emergency light (bolts are not included). Threaded conduit feed applications are found around the housing.

DIMENSIONS

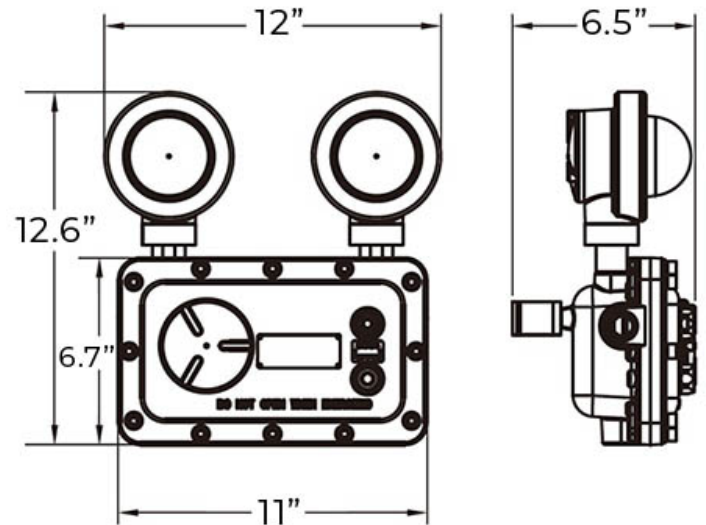

Weight : 15.00 lb

ELECTRICAL INFORMATION

State	150mA Voltage 108V, 60Hz		150mA, voltage 277V, 60Hz	
	Fully Charged	During Charge	Fully Charge	During Charging
Power (W)*	7	10	9	12
Power Factor	0.94	0.968	0.629	0.697
THD	15.73	12.44	43.22	35.82

3170 Scott St, Vista, CA 92081
 Phone: 877-352-3948 | Fax: 877-352-3949
info@exitlightco.com