

ROTATING EDGE LIT EXIT SIGN

Code: ELRT



The ELRT series reinvents the meaning of versatility and allows one sign to meet multiple mounting needs. Snap-in design, quality construction and elegant appearance make it a must-have.



Compatible Battery: B3A-48

FEATURES

- UL 924, NEC, OSHA and NFPA 101 Life Safety Code
- Listed for damp location
- Most versatile edge lit exit sign on the market
- Wall, sloped, high, or standard ceiling and recessed mount available
- Aluminum housing with high grade acrylic face
- Field Installable Arrows for Left, Right or Both directions.
- Long life LED illumination
- Test switch and charge rate indicator on battery backup models
- Dual 120/277 volt operation
- Please allow 3-5 days for black or white finishes - Call for rush orders

WARRANTY INFORMATION

Any component that fails due to manufacturer's defect is guaranteed for 1 year. The warranty only covers products installed and maintained in accordance with the instructions provided by their respective manufacturer and no warranty is made with respect to any of our products that are otherwise installed or maintained. For full warranty details, visit our Warranty Section.

Conformance to Codes and Standards

The ELRT series is UL listed and meets or exceeds the following: UL 924, NEC, OSHA and NFPA 101 Life Safety Code requirements.

ORDERING INFORMATION

Series	Housing Color	Sides	Voltage	Operation Type	Options
ELRT-R (Red)	A (Aluminum)	Single	120/277V	AC (AC Only)	RK (Recessed Mounting Kit)
ELRT-G (Green)	B (Black)	Double		BB (Battery Backup)	ST (Self Testing)
	W (White)				

CONSTRUCTION

The ELRT series housing is constructed of die-cast aluminum housing with an etched, clear acrylic panel. Double sided panel comes as mirrored configuration. Lettering is 6" high with 3/4" stroke. Aluminum housing is standard, black and white housing available.

ILLUMINATION

The ELRT series provides a long life LED illumination. The unit is constructed with a red or green high output LED board. Energy consumption is rated at less than 3 watts for the AC only model units. Battery backup units energy consumption is rated at less than 5 watts.

ELECTRICAL COMPONENTS

Dual voltage input 120/277 VAC operation. LED display indicates AC/ON. An external push button test switch allows maintenance personnel to quickly determine the operational status of the unit. Unit offers brown out, overload and short circuit protection.

EMERGENCY OPERATION

Upon failure of the normal utility power, an internal solidstate transfer switch automatically provides uninterrupted emergency operation for at least 90 minutes. The fully automatic solid-state, two-rate charger initiates battery charging to recharge a discharged battery in 24 hours.

BATTERY - BATTERY BACKUP

The ELRT series is designed with a 4.8 Volt maintenance-free NiCad battery. The battery is protected by a low voltage cut-off circuit. The operating temperature range for the battery is 32°F (0°C) to 104°F (40°C).

SELF-TESTING OPTION

This unit continuously self checks for proper operation. The multi-color LED indicator light will indicate the status after testing and adjust when corrected. The unit will self test in emergency mode for up to the full 90 minute duration to ensure proper operation during an actual power failure.

INSTALLATION

The ELRT is suitable for wall, sloped, high, or standard ceiling mounting. Recessed mounting option allows unit to be ceiling recessed for drop ceiling or new construction application only. Includes field installable directional arrow indicators. All hardware is included.

DIMENSIONS

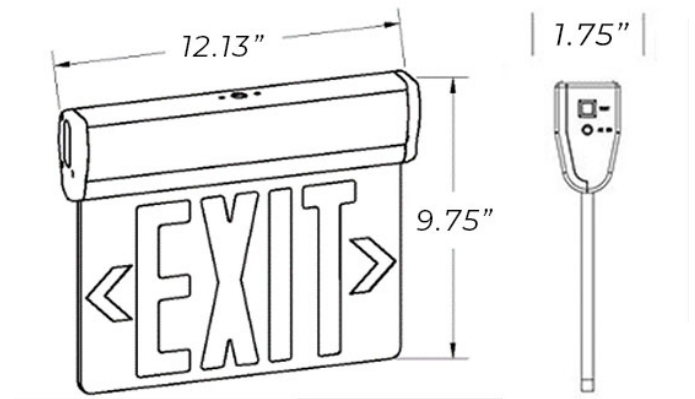

Weight : 5.00 lb

3170 Scott St, Vista, CA 92081
Phone: 877-352-3948 | Fax: 877-352-3949
info@exitlightco.com