



The ELCH-H2 Light light is a state of the art industrial emergency lighting product for extreme environments.



FEATURES

- UL 924 listed, UL Wet location listed, NSF Standard 2 Splash Zone, NEMA 250 (NEMA 4X classification), NFPA 101, NEC, BOCA, OSHA and IBC illumination standards
- UL Wet location listed
- Dual 120/277 VAC input
- Housing is rated for use in NEMA 4X and IP66 areas
- Constructed of gray impact-resistant Lexan with corrosion resistant hardware
- Hinged, removable cover allows for hands-free wiring
- Surge protection, brownout, AC lockout and low voltage disconnect features are standard
- Charging system is microprocessor driven with software embedded diagnostic routine and precision temperature compensation

WARRANTY INFORMATION

Any component that fails due to manufacturer's defect is guaranteed for 1 year. The warranty only covers products installed and maintained in accordance with the instructions provided by their respective manufacturer and no warranty is made with respect to any of our products that are otherwise installed or maintained. For full warranty details, visit our Warranty Section.

Conformance to Codes and Standards

The ELCH-H2 Industrial Light is UL listed and meets or exceeds the following: UL 924, UL wet location listed, IBC, BOCA, OSHA illumination standard, NFPA 101, NFPA 70, NSF Standard 2, NEMA 250, IEC 61951-1 Life Testing, and IEC529 requirements.

ORDERING INFORMATION

Series	Housing Color	Battery Voltage	Capacity	Environment	Options
ELCH-H2	G (Gray)	6VDC (6 Volt DC)	25W	WL (Wet Location 32°F to 104°F)	AM (Ammeter)
		12VDC (12 Volt DC)	50W	CA (Cold Ambient/Wet Listed -40°F to 104°F)	IF (Input Fuse)
		24VDC (24 Volt DC)	75W	HA (High Ambient/Wet Listed 32°F to 131°F)	BD (Battery / VAC Disconnect)
			100W	EA (Extreme Ambient/Wet Listed -40°F to 131°F)	SIT (Special Input Transformer)
					STA or STS (Self-Testing - Silent or Audible)
					TD (Time Delay)
					VM (Voltmeter)

CONSTRUCTION

The ELCH-H2 Industrial Emergency Light is constructed of impact resistant Lexan with corrosion resistant hardware. Features a hinged removable cover that allows hands-free wiring. One piece molded gasket with unexposed metallic hardware to prolong life in a highly corrosive area.

ILLUMINATION

The ELCH-H2 Emergency Light illumination is accomplished with two fully adjustable lamp heads internally mounted on the bottom of the unit for optimum path of egress illumination.

ELECTRICAL COMPONENTS

120/277 VAC dual voltage input with surge protection is standard on all models.

BATTERY - BATTERY BACKUP

The ELCH-H2 Hazard Emergency Light comes with a maintenance-free sealed lead calcium battery. Provides a minimum 90 minute emergency power at the lowest rated temperature of the model.

PHOTOMETRICS

Meets Life Safety Code illumination standard; average of 1.0 FC, no point less than 0.1 FC, max to min ratio of 40:1. Assumes open space with no obstructions, mounting height: 7.5' and reflectances: 80/50/20. Analysis based on independently tested photometric. Wall Mounted 7.5' AFF, 6 V 12 W Halogen Lamp Heads Represented 1 FC Average

SELF-TESTING OPTION

Unit will automatically perform NFPA required monthly and annual testing. Refer to user manual for details.

OPERATIONAL TEMPERATURE

Temperature Ratings	
Series	Temperature
Wet Location	0°C to 40°C / 32°F to 104°F
Cold Ambient/Wet Listed	-40°C to 40°C / -40°F to 104°F
High Ambient/Wet Listed	0°C to 55°C / 32°F to 131°F
Extreme Ambient/Wet Listed	-40°C to 55°C / -40°F to 131°F

INSTALLATION

The ELCH-H2 NEMA Rated Light is supplied with a standard mounting bracket.

DIMENSIONS

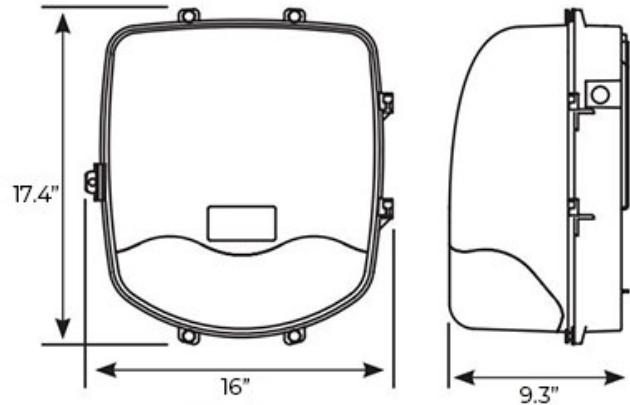

Weight : 16.00 lb

ELECTRICAL INFORMATION

6V and 12V, standard and high ambient units: (120 VAC) 0.319 A, (277 VAC) 0.142 A. 6V and 12V, cold ambient, and extreme ambient units: (120 VAC) 0.683 A, (277 VAC) 0.305A. 24V models: (120 VAC) 0.507 A, (277 VAC) 0.227 A