

IMPORTANT SAFEGUARDS

READ AND FOLLOW ALL SAFETY INSTRUCTIONS

When using electrical, basic safety precautions should always be followed including the following.

1. Disconnect power at fuse or circuit breaker before installing or servicing.
2. Do not mount in hazardous locations, or near gas or electric heaters.
3. Do not let power cords touch hot surface.
4. Equipment should be mounted in locations and at heights where it will not be subjected to tampering by unauthorized personnel.
5. The use of accessory equipment not recommend by the manufacturer may cause an unsafe condition.
6. Do not use this equipment for other than intended use.
7. All servicing should be performed by a qualified personnel only.
8. Allow battery to charge for 24 hours before first use.
9. The unit suit for wet location.

Use Flexible Conduit Only

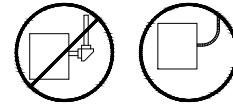

SAVE THESE INSTRUCTIONS

MAINTENANCE

Always disconnect power at fuse or circuit breaker before installing or servicing, servicing should be performed only by qualified personnel.

BATTERY: The battery no need maintenance. However, it should be tested periodically (see TESTING) and replaced when it no longer meet the required duration of 30 second or 90 minutes. The battery has a life expectancy of 4 years when used in a normal ambient temperature of 72 F.

Battery have to recharge if product keep in stock over 9 months, detail manual refer "BATTERY STOCK AND RECHARGE GUIDELINE".

OPERATION

1. Apply AC power to the unit, the indicator shows red.
2. Push the test switch, the LED indicator turns off and the LED board stays on .
3. After release the test switch, LED indicator turns back to red.

TROUBLE SHOOTING GUIDE

If LED board or LED indicator does not illuminate, check the following:

1. Check AC supply - verify that unit has 24 hours AC supply.
2. Battery is not connected.
3. Battery voltage too low- Permit unit to charge for 24 hours then re-test.
4. If above trouble shooting hints do not solve the problem, contact factory for assistance.

ROUTINE TESTING

National Electric Code (NEC) and NFPA life safety code regulations require that routine tests need to be performed as below:

Once every month, perform 30 seconds duration test, push in and hold the test switch to perform this test.

Once every 12 months, perform full 90 minutes test, disconnect AC power supply and transfer to emergency mode, the unit should stay on 90 minutes minimum.

Mounting Instructions

Fig 1

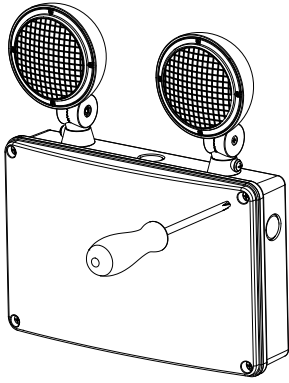

Remove screws to open the front cover.

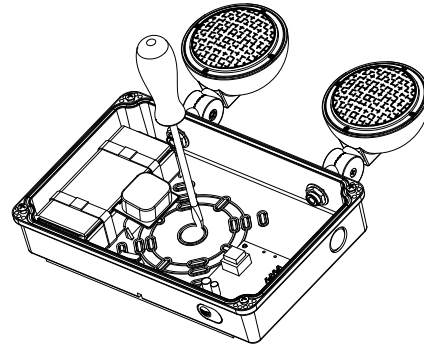

Knock out center and appropriate mounting screw holes on the back plate.

Fig 3

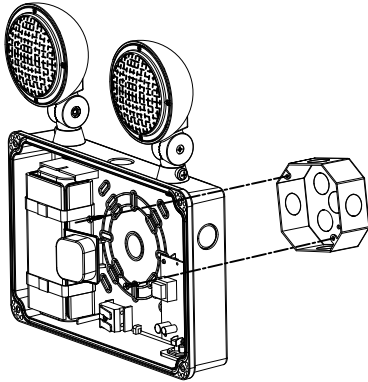

Feed building wires through the center hole, securely backplate to waterproof J-box by screws.

Fig 4

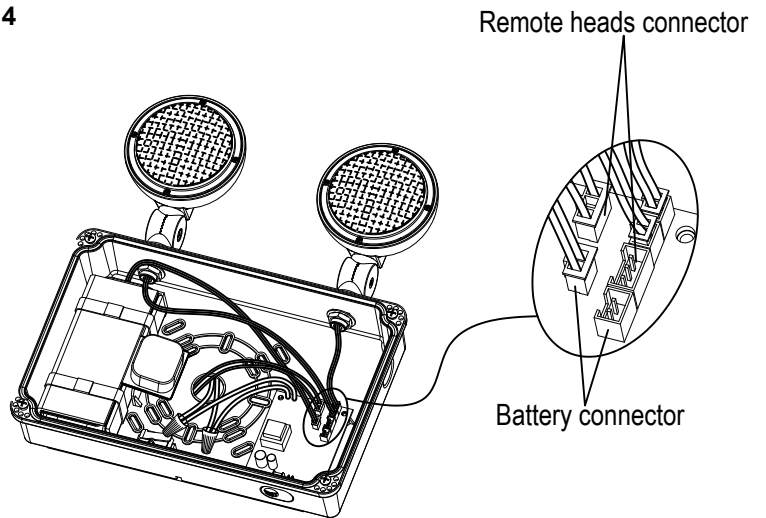

Remote heads connector

Battery connector

Wiring Diagram

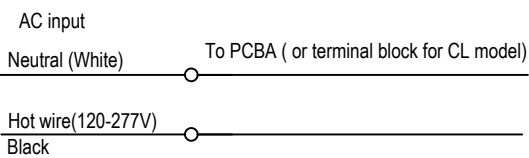

- A. Connect battery connector on PCBA, connect remote head if application.
- B. Connect the unit wires to building power supply wires using the wire nuts provided. Connect the white wire to neutral, connect the black wire to hot lead(120-277V), feed the wires and wire nuts back into J-box through back plate.
- C. Make correct heater pad connection if unit have heater pad option (see instruction for heater pad).
- D. Restore the front cover to housing.
- E. Restore power and press test button, LED heads will turn on.

REMOTE CAPABILITY

If fixture has remote capability option, Max. remote capability is 6VDC3W. Connect remote heads extension wire to remote wire, yellow is positive(+), purple is negative(-), connect wires using wire nuts.
 Notice: for constant output remote head, remote capability 1.5W max